

## SEMI-AUTOMATIC L-SEALER



Mod. SA 7050 PNE

### Models

SA 5040 PNE - SA 7050 PNE - SA 8065 PNE

Semi-automatic L-sealer made of steel sheets, treated and varnished with epossidic powder.

### Operation

After film setting by means of working table and roll holder, in accordance to product size, operator push product under upper film in sealing station. Sealing bar comes down by foot switch or automatically and perform seal around goods. Product is discharged by conveyor and next packing can be performed.

The sealer is suitable to pack half automatically the most various goods, single or multiple, using traditional hot sealable centrefold films.

Machine manufactured in different sizes, require small installation space, is practic in operation and absolutely reliable.

### Main features

- ▶ Discharging conveyor, adjustable in height, at 7.5 mt/min speed.
- ▶ Safety stop on sealing bar down motion, should on its trajectory be an obstacle.
- ▶ Impulse sealing controller by times, sealing blade on down or top sealing bar.
- ▶ Suitable film: PVC, polypropylene, and polyethylene.
- ▶ Average output: 300/900 pack/hour (purety indicative indication as depend type and dimension of product, consequence of package and type of film used).
- ▶ Products sizes max height 220 mm.



Via Puccini, 10 20028 S.Vittore Olona  
MILANO - ITALIA

Tel.+39.0331.421658 Fax +39.0331.511434

[www.vimacor.it](http://www.vimacor.it) [info@vimacor.it](mailto:info@vimacor.it)

## SEMI-AUTOMATIC L-SEALER

### Optional

- ▶ Synchronised push buttons for bar start.
- ▶ Electric production counter.
- ▶ Automatic trim recovery.
- ▶ Sealing with blade or wire on moving bar.

	<b>SA 5040 PNE</b>	<b>SA 7050 PNE</b>	<b>SA 8065 PNE</b>
Sealing bar	500 x 400 mm pneumatically operated and pedal or push-buttons or timer controlled	700 x 500 mm pneumatically operated and pedal or push-buttons or timer controlled	800 x 650 mm pneumatically operated and pedal or push-buttons or timer controlled
Max reel size	Ø 250 x 550 mm	Ø 250 x 650 mm	Ø 250 x 750 mm
Electrical	3 Ph + N + T 220/380 V 3 KW	3 Ph + N + T 220/380 V 3 KW	3 Ph + N + T 220/380 V 3 KW
Air consumption	6 Atm – 2 nl./cicle	6 Atm – 5 nl./cicle	6 Atm – 5 nl./cicle

All data are not engaging



Via Puccini, 10 20028 S.Vittore Olona  
MILANO - ITALIA  
Tel.+39.0331.421658 Fax +39.0331.511434  
[www.vimacor.it](http://www.vimacor.it) [info@vimacor.it](mailto:info@vimacor.it)

# SEMI-AUTOMATIC L-SEALER

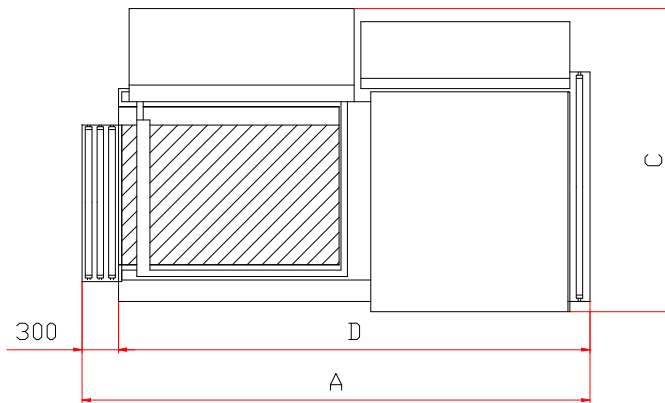
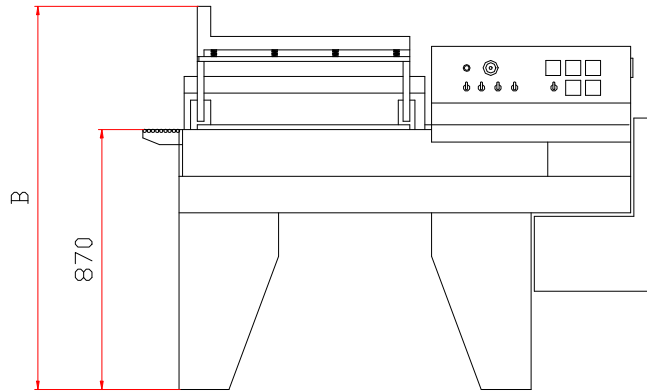

	<b>A</b>	<b>B</b>	<b>C</b>	<b>D</b>	<b>Kg.</b>
<b>5040</b>	1500	1300	830	1350	145
<b>7050</b>	2150	1300	990	1850	185
<b>8065</b>	2330	1300	1220	2030	220

Sizes in millimetres – Data not engaging



Via Puccini, 10 20028 S.Vittore Olona  
MILANO - ITALIA  
Tel.+39.0331.421658 Fax +39.0331.511434  
[www.vimacor.it](http://www.vimacor.it) [info@vimacor.it](mailto:info@vimacor.it)